

DATA SHEET

35 FRAME PLUNGER PUMPS



**Nickel Aluminum
Bronze Models: 3507, 3517**

Flushed Models: 3507C, 3517C

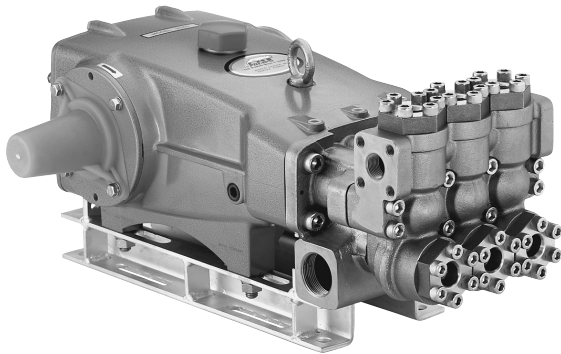

Model 3507 Shown
(Shaft protector included, mounting rails sold separately)

FEATURES

- Triplex design delivers high efficiency and low pulsation.
- Durable dual V-Packings are lubricated and cooled by pumped liquid.
- Special high-density, polished, concentric plungers provide a true wear surface and extended seal life.
- Standard NBR seals with alternative options for temperature and chemical compatibility
 - FPM – .0110
 - EPDM – .0220
 - IPFE– .0770
 - High Temp, 190°F – .3000
 - High Temp, 200°F – .3400 (Intermittent Run-Dry)

COMMON SPECIFICATIONS

	U.S.	Metric
Inlet Pressure Range	Flooded to 70 psi	Flooded to 4.8 bar
Max. Liquid Temperature	160° F	71° C
Above 130°F call Cat Pumps for inlet conditions and elastomer recommendations.		
Stroke	1.890"	48 mm
Crankcase Capacity	4.2 Qts.	4 l
Inlet Ports (2)	1 1/2" NPT(F)	1 1/2" NPT(F)
Flushing Ports (2) (3507C, 3517C)	1/4" NPT(F)	1/4" NPT(F)
Pulley Mounting	Either Side	Either Side
Shaft Diameter	1.378"	35 mm
Weight	152 lbs.	69 kg
Dimensions	24.51 x 18.11 x 9.72"	623 x 460 x 247 mm

*Pump minimum is 100 RPM.

SPECIFICATIONS

	U.S. Measure	Metric Measure
Model 3507, 3507C		
Flow	10 gpm	38 lpm
Pressure Range	100 to 5000 psi	6.9 to 345 bar
Pump RPM*	915 rpm	915 rpm
Bore	0.787"	20 mm
Discharge Ports (2)	3/4" NPT(F)	3/4" NPT(F)
Model 3517, 3517C		
Flow	14 gpm	53 lpm
Pressure Range	100 to 3000 psi	6.9 to 207 bar
Pump RPM*	800 rpm	800 rpm
Bore	0.984"	25 mm
Discharge Ports (2)	1" NPT(F)	1" NPT(F)

*Pump minimum is 100 RPM.

ELECTRIC HORSEPOWER REQUIREMENTS

MODELS	FLOW		PRESSURE						RPM
			psi 2000	psi 2500	psi 3000	psi 4000	psi 4500	psi 5000	
	U.S. gpm	lpm	bar 138	bar 172	bar 207	bar 275	bar 310	bar 345	
3507, 3507C	10.0	38.0	N/A	N/A	N/A	27.4	30.8	34.2	915
	9.0	34.0	N/A	N/A	N/A	24.7	27.8	30.8	824
	8.0	30.0	N/A	N/A	N/A	22.0	24.7	27.4	711
3517, 3517C	14.0	53.0	19.2	24.0	28.8	N/A	N/A	N/A	800
	12.0	45.0	16.5	20.6	24.7	N/A	N/A	N/A	685
	10.0	38.0	13.7	17.2	20.6	N/A	N/A	N/A	571

DETERMINING THE PUMP R.P.M.

$$\frac{\text{Rated gpm}}{\text{Rated rpm}} = \frac{\text{"Desired" gpm}}{\text{"Desired" rpm}}$$

DETERMINING THE REQUIRED H.P.

$$\text{Hp (Electric Brake)} = \frac{\text{gpm x psi}}{1460}$$

DETERMINING MOTOR PULLEY SIZE

$$\frac{\text{Motor Pulley O.D.}}{\text{Pump rpm}} = \frac{\text{Pump Pulley O.D.}}{\text{Motor rpm}}$$

See complete Drive Packages [Includes: pulleys, belts, hubs, key] Tech Bulletin 003.
Refer to pump **Service Manual** for repair procedure and additional technical information.

PARTS LIST

ITEM	PART NUMBER	MATL	PART NUMBER	MATL	DESCRIPTION	QTY
	3507/C		3517/C			
2	34021	STL	34021	STL	Key (M10x8x70)	1
5	125753	S	125753	S	Screw, HH Sems (M8x25)	8
8	44542	AL	44542	AL	Cover, Bearing (See Tech Bulletin 118)	2
9	815279	FBR	815279	FBR	Shim, Split, 2 pc	2
10	12398	NBR	12398	NBR	O-Ring, Bearing Cover - 70D	2
11	13296	NBR	13296	NBR	Seal, Oil, Crankshaft	2
15	29326	STL	29326	STL	Bearing, Roller	2
20	121467	TNM	121467	TNM	Rod, Connecting Assy (Incls: 21, 22, 23) [10/00]	3
21	126749	STCP R	126749	STCP R	Washer, Locking (M10)	3
22	126593	STCP R	126593	STCP R	Washer, Flat (M10)	6
23	122045	STZP	122045	STZP	Screw, HH (M10x55)	6
25	29325	FCM	29325	FCM	Crankshaft, Dual End (M48)	1
31	828710	PE	828710	PE	Protector, Oil Cap w/Foam Gasket	1
32	43211	ABS	43211	ABS	Cap, Oil Filler	1
33	14177	NBR	14177	NBR	O-Ring, Oil Filler Cap - 70D	1
34	126743	STCP R	126743	STCP R	Bolt, Eye (M12x1.75) (For Lifting Pump Only)	1
37	92241	—	92241	—	Gauge, Bubble Oil w/Gasket - 80D	1
38	44428	NBR	44428	NBR	Gasket, Flat Oil Gauge - 80D	1
40	125753	S	125753	S	Screw, HH Sems (M8x25)	8
48	25625	STCP	25625	STCP	Plug, Drain (1/4"x19BSP)	1
49	23170	NBR	23170	NBR	O-Ring, Drain Plug - 70D	1
50	45936	AL	45936	AL	Cover, Rear (See Tech Bulletin 118)	1
51	16612	NBR	16612	NBR	O-Ring, Cover - 70D	1
53	44487	AL	44487	AL	Crankcase Assy (Incls: 34, 54) (See Tech Bulletin 118)	1
54	27488	S	27488	S	Pin, Guide	2
56	27790	POP	27790	POP	Pan, Oil	1
59	92538	S	92538	S	Screw, HHC Sems (M6x16)	2
64	43864	CM	43864	CM	Pin, Crosshead	3
65	45118	SSZZ	45116	SSZZ	Rod, Plunger	3
69	126587	STCP R	126587	STCP R	Washer, Oil Seal	3
70	100488	NBRS	100488	NBRS	Seal, Oil, Crankcase	3
	44739	FPM	44739	FPM	Seal, Oil, Crankcase	3
75	43506	S	43865	S	Slinger, Barrier	3
88	45675	S	45676	S	Washer, Keyhole	3
90	43945	CC	43866	CC	Plunger (M20x145) Model 3507, Plunger (M25x145) Model 3517	3
95	89779	S	89778	SS	Stud, Retainer (M7x123) Model 3507, Stud, Retainer (M10x135) Model 3517	3
96	20184	PTFE	20189	PTFE	Back-up-Ring, Plunger Retainer	3
97	14190	NBR	11345	NBR	O-Ring, Plunger Retainer - 70D	3
	14161	FPM	11375	FPM	O-Ring, Plunger Retainer	3
	◆ 48239	EPDM	◆ 701490	EPDM	O-Ring, Plunger Retainer	3
98	44069	SS	44085	SS	Gasket, Plunger Retainer (M7) Model 3507, Gasket, Plunger Retainer (M10) Model 3517	3
99	44068	SS	44084	SS	Retainer, Plunger (M7) Model 3507, Retainer, Plunger (M10) Model 3517	3
100	814279	PVDF	814279	PVDF	Retainer, Seal [See Tech Bulletin 105]	3
101	44095	—	44096	—	Wick	3
104	43875	NBR	43875	NBR	O-Ring, Adapter - 70D	3
	44826	FPM	44826	FPM	O-Ring, Adapter - 70D	3
	◆ 701656	EPDM	◆ 701656	EPDM	O-Ring, Adapter - 70D	3
105	44073	NAB	44088	NAB	Adapter, LPS	3
106	44071	NBR	44086	NBR	Seal, LPS w/SS-Spg	3
	44381	FPM	45846	FPM	Seal, LPS w/SS-Spg	3
	701974	SFTB	701944	SFTA	Seal, LPS w/SS-Spg	3
107	44074	SS	44089	SS	Washer, LPS	3
110	44206	NAB	44206	NAB	Manifold, Inlet	1
	125970	NAB	125970	NAB	Manifold, Inlet, Flushed (1/4" Inlet Port) 3507C, 3517C	1
112	11379	NBR	11379	NBR	O-Ring, Inlet Manifold - 70D	3
	14183	FPM	14183	FPM	O-Ring, Inlet Manifold	3
	◆ 701491	EPDM	◆ 701491	EPDM	O-Ring, Inlet Manifold - 70D	3
117	44585	S	44585	S	Screw, HSH (M14x40)	4
123	12391	NBR	12391	NBR	O-Ring, V-Packing Cylinder - 70D	3
	13266	FPM	13266	FPM	O-Ring, V-Packing Cylinder - 70D	3
	◆ 701657	EPDM	◆ 701657	EPDM	O-Ring, V-Packing Cylinder - 70D	3
124	44075	NAB	44090	NAB	Cylinder, V-Packing	3
126	44076	NAB	44091	NAB	Adapter, Female	3
127	44607	STG	44610	STG	V-Packing Model 3507, V-Packing Model 3517	9/6
128	44077	NAB	44092	NAB	Adapter, Male	3
155	17622	NBR	11379	NBR	O-Ring, V-Packing Spacer	6
	11719	FPM	14183	FPM	O-Ring, V-Packing Spacer	6
	◆ 701654	EPDM	◆ 701491	EPDM	O-Ring, V-Packing Spacer - 70D	6
156	28675	PTFE	28243	PTFE	Back-up-Ring, V-Packing Spacer	6
157	46668	SS	44093	NAB	Spacer, V-Packing	3
162	21985	PTFE	21985	PTFE	Back-up-Ring, Seat	6
163	26089	NBR	26089	NBR	O-Ring, Seat - 80D	6
	11377	FPM	11377	FPM	O-Ring, Seat - 80D	6
	◆ 46647	EPDM	◆ 46647	EPDM	O-Ring, Seat - 80D	6
164	44080	SS	44080	SS	Seat	6
166	44081	SS	44081	SS	Valve	6
167	44082	SS	44082	SS	Spring	6
168	44735	PVDF	44735	PVDF	Retainer, Spring	6
170	44794	SS	44794	SS	Washer, Spring Retainer	6
171	44793	SS	44793	SS	Spring, Coil, Valve Plug	6
172	15853	NBR	15853	NBR	O-Ring, Valve Plug - 70D	6

EXPLODED VIEW

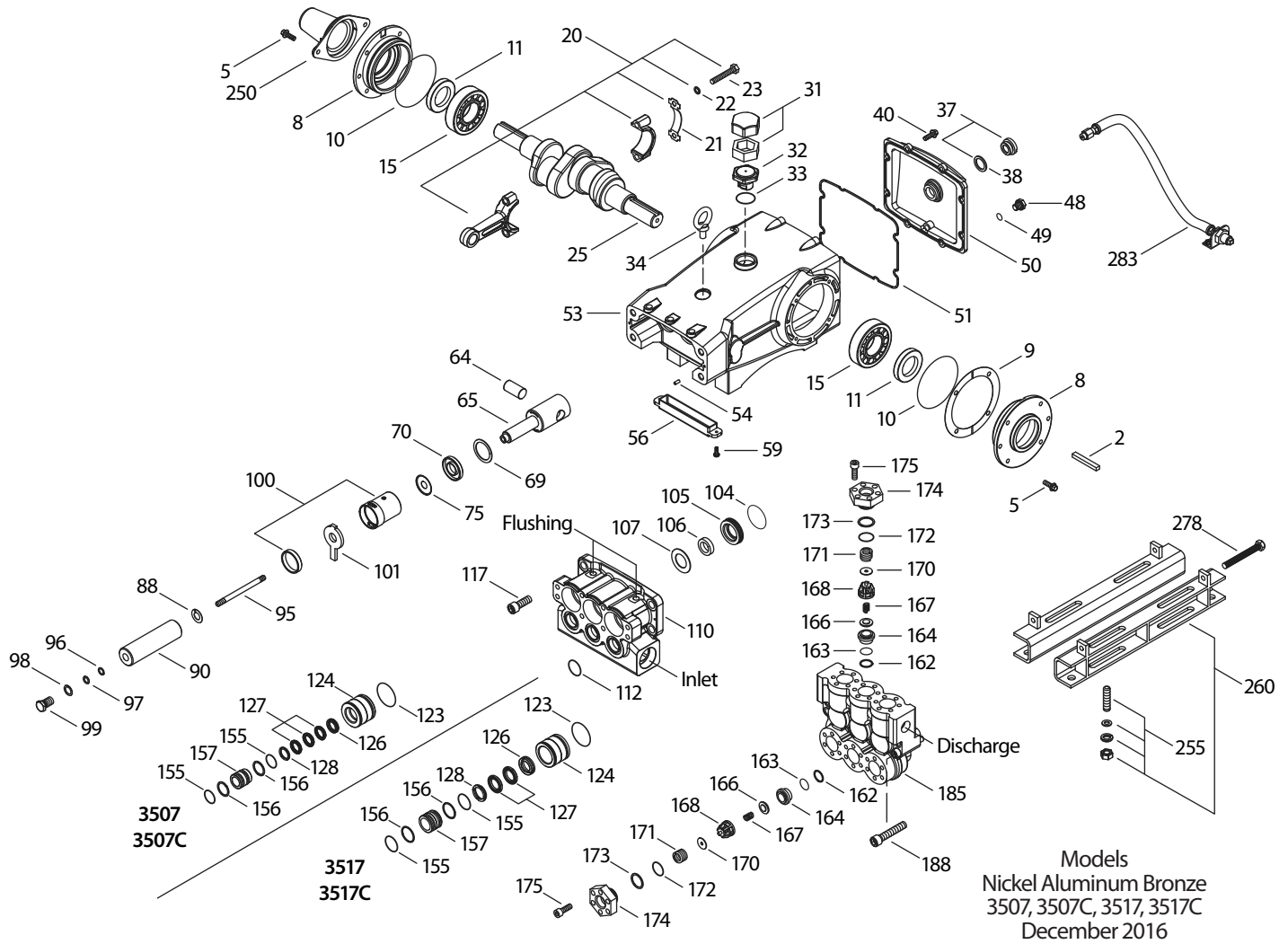

ITEM	PART NUMBER	MATL	PART NUMBER	MATL	DESCRIPTION	QTY
	3507/C		3517/C			
	11720	FPM	11720	FPM	O-Ring, Valve Plug - 70D	6
	◆ 701481	EPDM	◆ 701481	EPDM	O-Ring, Valve Plug - 70D	6
173	20224	PTFE	20224	PTFE	Back-up-Ring, Valve Plug	6
174	44795	NAB	44795	NAB	Plug, Valve	6
	76795	NAB	76795	NAB	Plug, Valve with 1/4" NPT(F) Port	1
175	87951	S	87951	S	Screw, HSH (M10x30)	36
185	46561	NAB	46565	NAB	Manifold, Discharge [10/99]	1
188	89981	S	89981	S	Screw, HSH (M12x70)	8
250	44516	NY	44516	NY	Protector, Shaft, w/2 Screws, Lockwashers and Washers (Included with Pump)	1
255	34018	STZPR	34018	STZPR	Assy, Direct Mount	1
—	34039	SS	34039	SS	Assy, Direct Mount	1
260	92674	STZPR	92674	STZPR	Mounting, Rail, Assy (Incls: 34018)	1
275	990013	STL	990013	STL	Hub, 'B' 35mm w/Keyway [See Tech Bulletin 003]	1
278	80540	ZP	80540	ZP	Screw, HH (M12x100) (Rail Adjusting Screw)	1
279	30278	STZP	30278	STZP	Oiler (1 oz.) (Not Shown)	3
283	34314	—	34314	—	Kit, Oil Drain (3/8" x 48")	1
290	6124	—	6124	—	Gasket, Liquid (3 oz.)	1
299	816755	NAB	816750	NAB	Head, Complete w/NBR Seals and O-Rings (Models 3507 and 3517 only)	1
300	31037	NBR*	31038	NBR*	Kit, Seal (Incls: 97,104,106,112,123,127,155,156)	1
	33265	FPM*	31266	FPM*	Kit, Seal (Incls: 97,104,106,112,123,127,155,156)	1
	76579	EPDM*	◆ 76138	EPDM	Kit, Seal (Incls: 97,104,106,112,123,127,155,156)	1
310	34151	NBR	34151	NBR	Kit, Valve (Incls: 162,163,164,166,167,168,170,172,173)	2
	701798	FPM	701798	FPM	Kit, Valve (Incls: 162,163,164,166,167,168,170,172,173)	2
	◆ 701799	EPDM	◆ 701799	EPDM	Kit, Valve (Incls: 162,163,164,166,167,168,170,172,173)	2
—	819000	F	819000	F	Assembly, Crankcase, Cast Iron Conversion	1
—	6100	—	6100	—	Oil, Case (12 Bottles) ISO 68 Hydraulic (Fill to specified crankcase capacity prior to start-up)	1

Bold print part numbers are unique to a particular pump model. *Italics are optional items.* [] Date of latest production change.

◆ Silicone Oil/Grease Required R Components comply with RoHS Directive. *Review material codes for individual items (STG generally may be used as alternate).

See Tech Bulletins 002, 003, 024, 035, 036, 041, 043, 052, 053, 068, 069, 074, 080, 083, 105 and 118 for additional information.

MATERIAL CODES (Not Part of Part Number): ABS=ABS Plastic AL=Aluminum CC=Ceramic CM=Chrome-Moly EPDM=Ethylene Propylene Diene Monomer F=Cast Iron FBR=Fiber FCM=Forged Chrome-moly FPM=Fluorocarbon NAB=Nickel Aluminum Bronze NBR=Medium Nitrile (Buna-N) NBR5=Buna, Silicone Free NY=Nylon PE=Polyethylene POP=Polypropylene PTFE=Pure Polytetrafluoroethylene PVDF=Polyvinylidene Fluoride S=304SS SFTA=Special Blend PTFE Tan SFTB=Special Blend PTFE Black SS=316SS STG=Special Blend PTFE White SSZZ=316SS/Zamak STL=Steel STCP=Steel/Chrome Plated STZP=Steel/Zinc Plated TNM=Special High Strength ZP=Zinc Plated

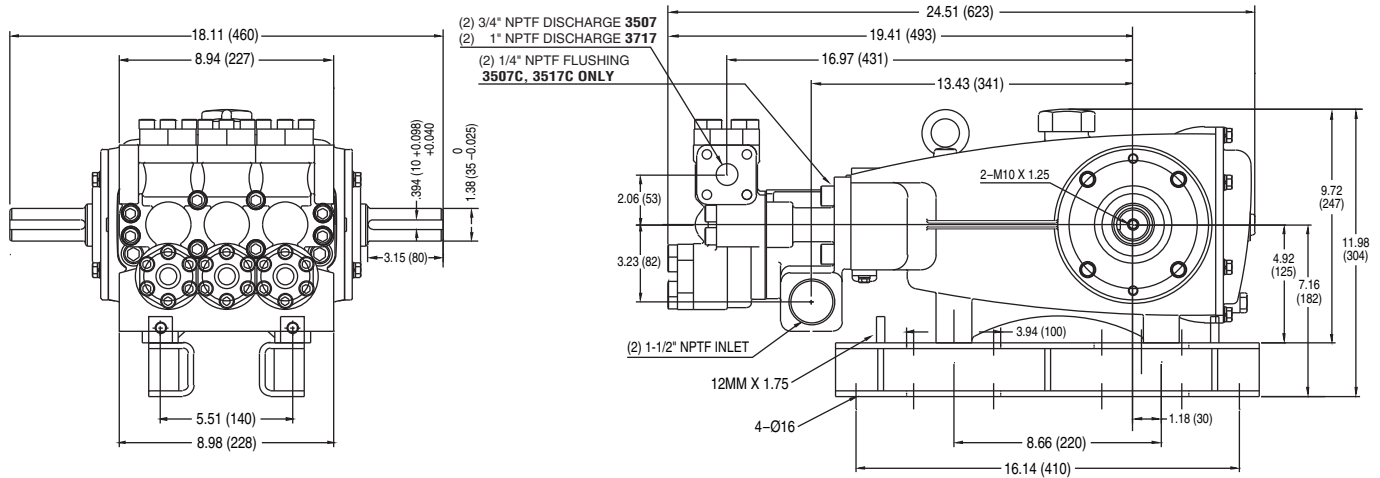

Models 3507, 3507C, 3517, 3517C

⚠ CAUTIONS AND WARNINGS

All High Pressure Systems require a primary pressure regulating device (i.e. regulator, unloader) and a secondary pressure relief device (i.e. pop-off valve, relief valve). Failure to install such relief devices could result in personal injury or damage to pump or property. Cat Pumps does not assume any liability or responsibility for the operation of a customer's high pressure system.

Read all CAUTIONS and WARNINGS before commencing service or operation of any high pressure system. The CAUTIONS and WARNINGS are included in each service manual and with each Accessory Data sheet. CAUTIONS and WARNINGS can also be viewed online at www.catpumps.com/cautions-warnings or can be requested directly from Cat Pumps.

WARRANTY

View the Limited Warranty on-line at www.catpumps.com/warranty.



CAT PUMPS

1681 - 94TH LANE N.E. MINNEAPOLIS, MN 55449-4324
 PHONE (763) 780-5440 — FAX (763) 780-2958
 e-mail: techsupport@catpumps.com
www.catpumps.com