

Pump Pompa	Pressure Pressione		Volume Portata				RPM giri/min		Power Potenza			
			l/min		GPM				HP		kW	
	bar	PSI	50 Hz	60 Hz	50 Hz	60 Hz	50 Hz	60 Hz	50 Hz	60 Hz	50 Hz	60 Hz
NMT1220ES	200	3000	12.5	15.0	3.3	4.0	1450	1740	6.4	7.5	4.7	5.7
NMT1520ES	200	3000	15.0	18.0	4.0	4.7	1450	1740	7.7	9.2	5.7	6.8
NMT1820ES	200	3000	18.0	21.4	4.8	5.6	1450	1740	9.2	11.0	6.8	8.1
NMT2120ES	200	3000	21.0	25.0	5.5	6.6	1450	1740	10.7	12.8	7.9	9.4

Dimensioni d'ingombro

Overall dimensions

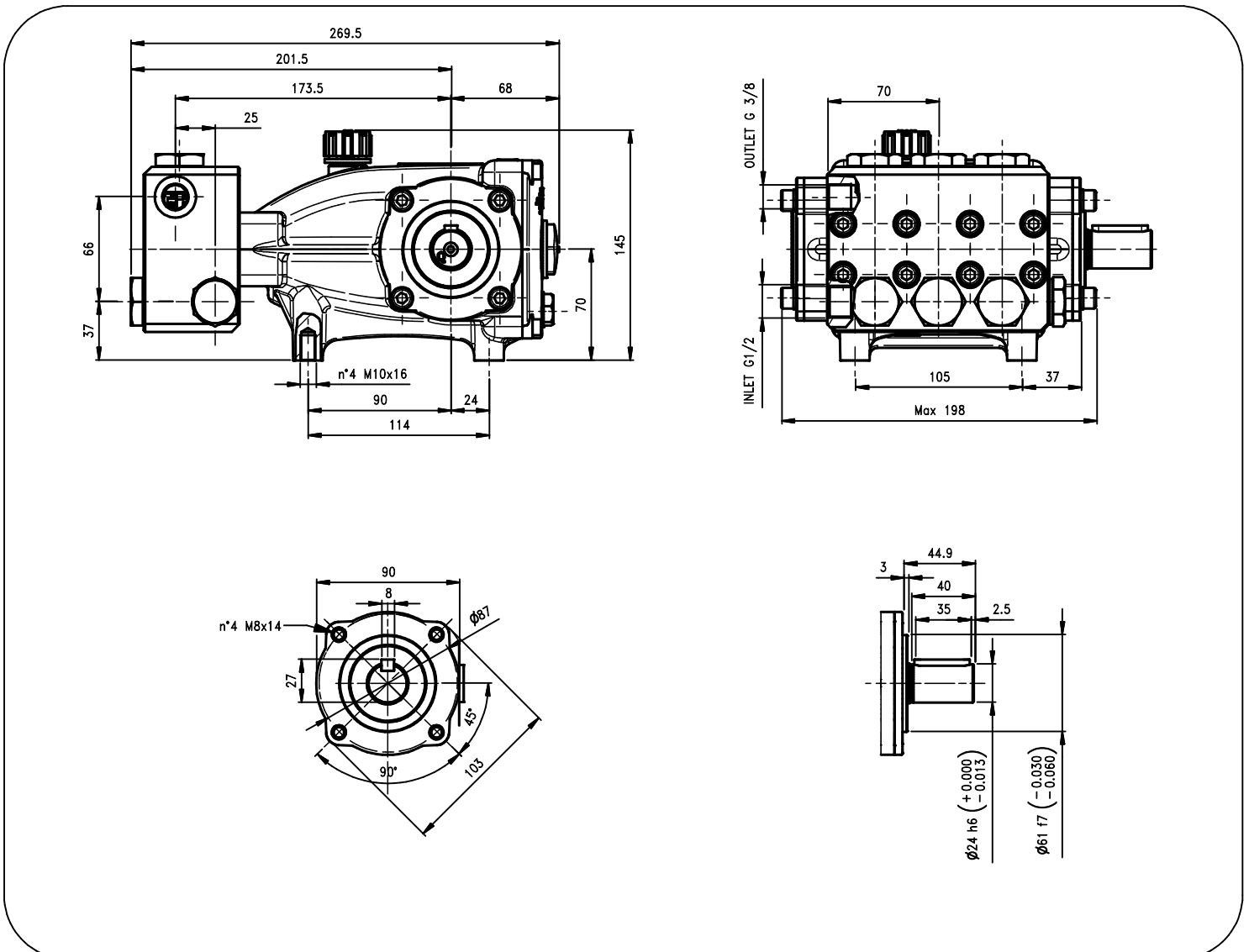

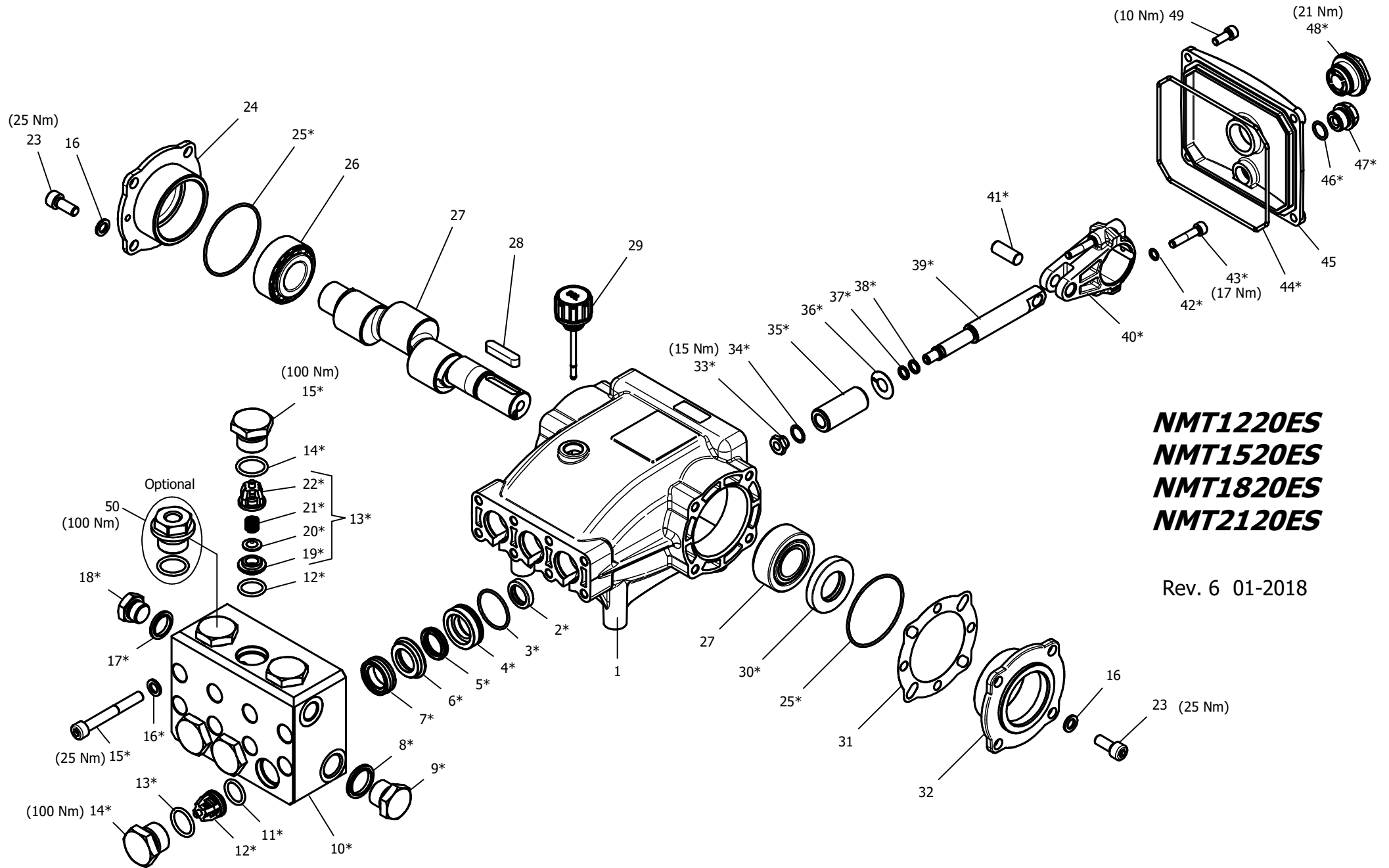

***NMT1220ES***  
***NMT1520ES***  
***NMT1820ES***  
***NMT2120ES***

Rev. 6 01-2018

**HAWK**  
**Pompe NMT ES serie 2012**  
**NMT ES Pumps 2012 series**

## NMT ES 2012 SERIES

### ORDINARY MAINTENANCE KIT / KIT MANUTENZIONE ORDINARIA

KIT	Item Pos.	Part Number Codice	Description	Descrizione	Q.TY by Pump Q.TA per Pompa	NMT1220ES	NMT1520ES	NMT1820ES	NMT2120ES
A	3- 4- 5- 7	1.904-469.0	PLUNGER SEALS DIA. 20 mm	GUARNIZIONI PISTONE Ø20	1				
B	11- 12- 13 (19- 20- 21 22)	1.905-583.0	COMPLETE VALVE	VALVOLA COMPLETA	1	•	•	•	•

### EXTRAORDINARY MAINTENANCE KIT / KIT MANUTENZIONE STRAORDINARIA

KIT	Item Pos.	Part Number Codice	Description	Descrizione	Q.TY by Pump Q.TA per Pompa	NMT1220ES	NMT1520ES	NMT1820ES	NMT2120ES
C	3- 4- 5- 6- 7	1.905-582.0	COMPLETE SEALS PACKING DIA. 20 mm	PACCO COMPLETO GUARNIZIONI PISTONE Ø20	1				
D	33- 34- 35 36- 37- 38	1.099-846.0	PLUNGER DIA. 20 mm	PISTONE Ø20	3				
E	2	1.099-751.0	PLUNGER OIL SEALS	ANELLI TENUTA OLIO ASTA	1				
F	25- 30- 44 46- 47- 48	1.905-542.0	KIT CRANKCASE SEALS	KIT TENUTE CARTER	1				
G	3- 4- 5- 6- 7 8- 9- 10- 11 12- 13- 14 15- 16- 17 18 (19- 20 21- 22)	1.099-848.0	COMPLETE MANIFOLD	TESTATA COMPLETA	1	•	•	•	•
H	33- 34- 37 38- 39- 40 41- 42- 43	1.905-581.0	CONNECTING ROD PLUNGER ROD ASSY	PREMONTATO ASTA-BIELLA PISTONE	3				
I	13- 14	1.904-323.0	VALVE PLUG ASSY	PREMONTATO TAPPO VAM	6				

“Q.TY by Pump” => Necessary quantity to repair one pump  
 “Q.TA’ per Pompa” => Quantità necessaria per riparare una pompa

### OPTIONAL

Item Pos.	Part Number Codice	Description	Descrizione	Q.TY by Pump Q.TA per Pompa	NMT1220ES	NMT1520ES	NMT1820ES	NMT2120ES
50	9.853-426.0	THREADED BRASS PLUG G1/4	PREMONTATO TAPPO FORATO	1	•	•	•	•

### TOOL KIT

Part Number Codice	Description	Descrizione	Q.TY by Pump Q.TA per Pompa	NMT1220ES	NMT1520ES	NMT1820ES	NMT2120ES
1.099-667.0	TOOL-KIT	TOOL-KIT	1	•	•	•	•
1.904-414.0	OIL SEAL EXTRACTOR TOOL-KIT	TOOL-KIT ESTRAZIONE PARAOLIO	1	•	•	•	•

### IMPORTANT

### IMPORTANTE

\* Part available **ONLY** in kit  
Disponibile **SOLO** in kit

(...) Parts pre-assembled  
Parti pre-assemblate

### PARTS LIST LISTA PARTI

Item Pos	Part Number Codice	Description	Descrizione	KIT	Q.TY Q.TÀ	NMT120ES	NMT1520ES	NMT1820ES	NMT2120ES
1	9.850-375.0	CRANKCASE	CARTER		1				
2*		PLUNGER OIL SEAL	ANELLO RADIALE	E	3				
3*		"O" RING Ø1.78X31.47	"O" RING Ø1.78X31.47	A-C-G	3				
4*		PRESSURE RING 20MM	PRESSORE "U" Ø20	C-G	3				
5*		LOW PRESSURE "U" SEAL, DIA.20MM	ANELLO TENUTA "U" Ø20	A-C-G	3				
6*		INTERMED. RING 20MM	DIFFUSORE INTER. Ø20	C-G	3				
7*		HIGH PRESSURE "U" SEAL, DIA.20MM	ANELLO TENUTA "U" Ø20	A-C-G	3				
8*		BONDED SEAL G1/2 STAINLESS STEEL	BONDED SEAL G 1/2 INOX	G	1				
9*		PLUG G1/2 STAINLESS STEEL	TAPPO G1/2 INOX	G	1				
10*		MANIFOLD HOUSING STAINLESS STEEL	TESTATA INOX	G	1				
11*		"O" RING Ø2.62X17.13	"O" RING Ø2.62X17.13	B-G	6				
12*		VALVE ASSEMBLY	VALVOLA PREMONTATA	B-G	6				
13*		"O" RING Ø2.62X20.29	"O" RING Ø2.62X20.29	B-G-I	6				
14*		VALVE PLUG STAINLESS STEEL	TAPPO VALVOLA INOX	G-I	6	•	•	•	•
15*		MANIFOLD STUD BOLT STAINLESS STEEL	VITE TCEI M8X65 INOX A2 70	G	8				
16*		WASHER Ø8,5 STAINLESS STEEL	ROSETTA Ø8.5 INOX	G	16				
17*		BONDED SEAL G3/8 STAINLESS STEEL	BONDED SEAL G 3/8 INOX	G	1				
18*		PLUG G3/8 STAINLESS STEEL	TAPPO G3/8 INOX	G	2				
19*		VALVE SEAT	SEDE VALVOLA	B-G	6				
20*		VALVE PLATE	PIATTELLO VALVOLA	B-G	6				
21*		VALVE SPRING	MOLLA VALVOLA	B-G	6				
22*		VALVE CAGE	GABBIA VALVOLA	B-G	6				
23	9.851-476.0	HEX SOCKET SCREW M8X20 STAINLESS STEEL	VITE TCEI M8X20 INOX A2 70		8				
24	9.850-626.0	CLOSED BEARING HOUSING	FLANGIA CHIUSA		1				
25*		"O" RING Ø1.78X60.05	"O" RING Ø1.78X60.05	F	2				
26	9.850-349.0	ROLLER BEARING 33205	CUSCINETTO A RULLI 33205		2				
27	9.850-175.0	SINGLE - ENDED SHAFT	ALBERO SEMPLICE P.D.F.		1	•			
	9.850-177.0	" " "	" " "		1		•		
	9.850-178.0	" " "	" " "		1			•	
	9.850-179.0	" " "	" " "		1				•
28	9.850-446.0	CRANKSHAFT KEY	CHIAVETTA		1				
29	9.851-286.0	OIL DIP STICK	TAPPO LIVELLO OLIO		1				
30*		CRANKSHAFT SEAL	ANELLO RADIALE	F	1	•	•	•	•
31	9.850-547.0	SHIM	DISTANZIALE		1				
32	9.850-625.0	BEARING HOUSING	FLANGIA		1				

Item Pos	Part Number Codice	Description	Descrizione	KIT	Q.TY Q.T À	NMT1220ES	NMT1520ES	NMT1820ES	NMT2120ES
33*		PLUNGER NUT STAINLESS STEEL	DADO PISTONE INOX	D-H	3				
34*		SPACER Ø 11.2/15X0.5 STAINLESS STEEL	ROSETTA Ø 1.2/15X0.5 INOX	D-H	3				
35*		PLUNGER 20MM	PISTONE Ø20	D	3				
36*		SPACER Ø 11.3/24X0.5 STAINLESS STEEL	ROSETTA Ø 1.3/24X0.5 INOX	D	3				
37*		"O" RING Ø1.78X7.66	"O" RING Ø1.78X7.66	D-H	3				
38*		TEFLON RING	ANELLO ANTIESTRUSIONE	D-H	3				
39*		PLUNGER ROD STAINLESS STEEL	ASTA PISTONE INOX	H	3				
40*		CONNECTING ROD	BIELLA	H	3				
41*		CONNECTING ROD PIN	SPINOTTO	H	3	•	•	•	•
42*		SPRING WASHER Ø6	ROSETTA ELASTICA Ø6	H	6				
43*		CONNECTING ROD SCREW M6X30	VITE M6X30	H	6				
44*		"O" RING Ø 2.62X126.67	"O" RING Ø 2.62X126.67	F	1				
45	9.850-388.0	CRANKCASE COVER	COPERCHIO POSTERIORE		1				
46*		"O" RING Ø1.78X14	"O" RING Ø1.78X14	F	1				
47*		BRASS PLUG G 3/8	TAPPO G 3/8	F	1				
48*		SIGHT GLASS, G3/4	SPIA LIVELLO OLIO G3/4	F	1				
49	9.851-475.0	COVER SCREW M6X16 STAINLESS STEEL	VITE M6X16 INOX A2 70		4				