



P.A. – S.p.A. – EQUIPAGGIAMENTI TECNICI DEL LAVAGGIO

VIA MILANO, 13 – CASELLA POSTALE 115 – 42048 RUBIERA (REGGIO EMILIA) – ITALY
 Tel. +39 0522 623611 – Fax. +39 0522 629600 – R.E.A. RE 156319 – R.I. RE11535 – Mecc. RE 013446
 C.F. e P. IVA 01035950359 – Cap. Soc. i.v. € 750.000,00 – Codice Identificativo C.E.E. IT 01035950359
 ART. 2497 – BIS C.C. DIREZIONE E COORDINAMENTO BENETTI srl R.I. TRIB. DI RE 01480690351
 Web: <http://www.pa-etl.it> – E-mail: info@pa-etl.it



VB 200/280 Unloader valve

Technical manual: E 269

Pressure regulating unloader valve. At gun closure the water flow is discharged in bypass, lowering the pressure in the circuit upstream of the valve.

DN 25

1”G FF

- **60.4300.00** VB 200/280



- High flow rate
- Brass body and Sst internal parts
- Adjustable with screw and counter nut to secure the working pressure
- Slots for screw fastening

Technical specifications

| Construction material | | | | Brass body and Sst internal parts | | | | | | | | |
|-----------------------|----------------|------|----------------------|-----------------------------------|-----------------------------|-----|--|----------------|-------|--------|-----|---------------------|
| Rated temperature (1) | | | | 90°C (195°F) | | | | | | | | |
| Part number | Rated pressure | | Permissible pressure | | Minimum adjustable pressure | | % decrease of pressure to reset working pressure (2) | Max. Flow Rate | | Weight | | Inlet Outlet Bypass |
| | bar | Psi | bar | Psi | bar | Psi | % | l/min | USGpm | g | lbs | |
| 60.4300.00 | 280 | 4050 | 310 | 4500 | 28 | 410 | 22 | 200 | 53 | 3440 | 7.6 | G 1” F |

- 1) The valve has been designed for a continuous use at a water temperature of 60°C. It can resist for short periods at a maximum temperature of 90°
- 2) When the valve is in bypass mode, this is the decrease of pressure that has to occur in the circuit downstream of the valve, in order that the valve can restore the working pressure in the system. The indicated figure is expressed as a percentage of the pressure setting (working pressure).

At gun closure, a pressure increase occurs in the circuit downstream of the valve. This pressure increase is used to activate the valve and discharge all the flow in bypass. The value of the pressure increase can not be calculated. It depends on the correct setting of the valve (see PRESSURE ADJUSTMENT/SETTING) and on the layout of the system: flow rate, working pressure, length and characteristic of the tubes, closing time of the gun.

DIMENSIONAL DRAWING

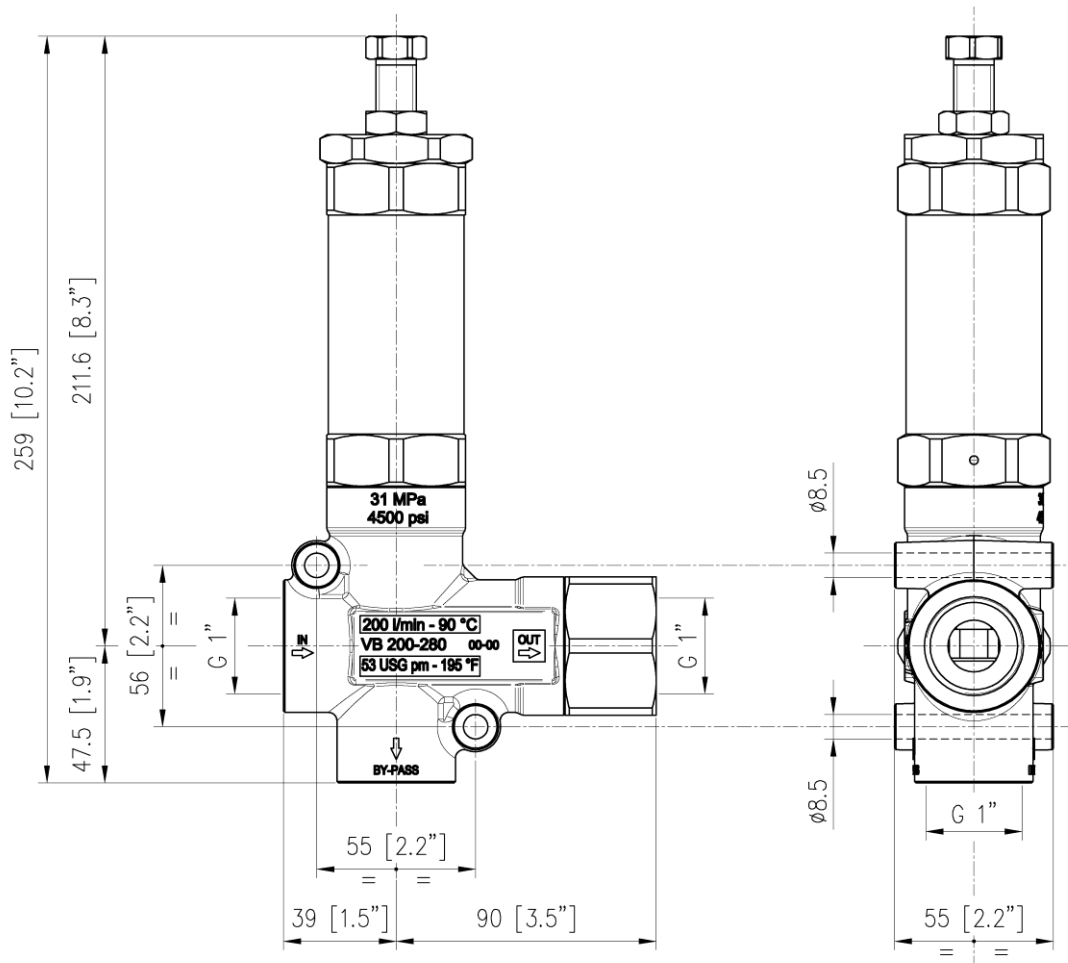

SELECTION

This product is intended to be incorporated on a finished machine. This product is to be utilized with clean fresh water, even slightly additivated with normal detergents. For use involving different or corrosive liquids, contact the PA Technical department. Appropriate filtration should be installed when using impure liquids. Choose the valve in line with the working data of the machine where to be installed (permissible pressure, maximum flow rate and rated temperature of the system). In any case, the pressure of the machine must not exceed the permissible pressure imprinted on the valve.

OPERATIONS

The valve regulates the maximum pressure of the system by varying the flow discharged through the bypass. The adjustment is made by altering, by means of a piston, the position of a shutter which partially closes the bypass opening. At gun closure, a check valve closes isolating the part of the circuit downstream of the valve: the pressure increase that remains trapped is used to activate the complete aperture of bypass. All the flow supplied by the pump is therefore discharged at low pressure through the bypass and the pump works at low pressure.

INSTALLATION

This accessory, on a system that produces hot water, must be fitted upstream of the heat generator. On a system that generates hot water, it is advisable to fit in accessories that limit the accidental increase of fluid temperature.

Always install a safety valve.

It is recommended to use a nozzle with a flow rate that, at gun opened, allows to discharge from the valve bypass at least 5% of the flow supplied by the pump in order to obtain a constant pressure figure, and easy adjustment and to avoid troublesome pressure spikes at gun closure.

If the nozzle wears out, the working pressure decreases. To reset pressure back to work level, it is necessary to replace the worn out nozzle. When a new nozzle is fitted, re-setting of the system to its original working pressure is necessary.

DISCHARGE SYSTEM AND WATER ADDUCTION

It is recommended to install the valve with bypass discharge into a tank. We advise also that the tank be fitted with deflectors in order to reduce eventual turbulence and air bubbles, generated by the immission of the bypass flow, which could be harmful for the pump. With elevated flow or near to the maximum flow of the valve, the installation with bypass recycle direct to the pump could cause harmful pressure spikes, resulting extremely dangerous for the pump.

PRESSURE REGULATION/SETTING

The desired working pressure must be adjusted while the system is in operation and gun opened. Alter the pressure by screwing or unscrewing the adjustment screw. The operation is easier if the correct nozzle has been chosen (see paragraph "installation"). Pressure is increased by rotating the adjustment knob. In case pressure does not increase despite turning of the knob, **do not force**, but check that the nozzle flow rate/pressure ratio is correct.

ATTENTION: The nut in position 16 is a mechanical security device that limits the maximum pressure; it must absolutely not be removed.

TROUBLE SHOOTING: CAUSES AND SOLUTIONS

| PROBLEMS | PROBABLE CAUSES | SOLUTIONS |
|--|---|--|
| Frequent unloader recycles | Damaged check valve O ring Leaking connections Restricted bypass | Replace Check and renew Clean or adapt |
| Unloader does not reach pressure | Piston O rings worn out Debris between seat and shutter Worn out nozzle | Replace Clean the seat Replace |
| Pressure peaks | There is not a min of 5% of total flow in bypass Excessive flow in bypass Spring totally compressed | Reset Change type of valve or adjust passages Loosen screw and change nozzle |
| Unloader does not bypass at low pressure | Jammed check valve Debris on check valve | Clean or replace Clean |

MAINTENANCE

STANDARD: every 400 working hours, check and lubricate the seals with water resistant grease.

SPECIAL: every 800 working hours, control the wear of the seals and internal parts and if necessary, replace with original PA parts taking care, during installation, to lubricate with water resistant grease.

Maintenance has to be carried out by specialized technicians.

The manufacturer is not to be considered responsible for damage as a result from incorrect fitting and maintenance.

REGULATIONS : see Norm Manual

For a correct utilization, follow the directions described in this manual and re-print them on the Use and Maintenance manual of the machine.

If needed ask for the original Conformity Declaration for the accessory chosen. The present manual is valid for all unloader valves named **VB 200/280**.

Technical data, descriptions and illustrations are indicative and liable to modification without notice.

| | |
|--|---------------|
| Instruction manual, maintenance, installation, spare parts. | n. 12.9269.50 |
|--|---------------|



P.A. S.p.A.

Via Milano, 13
42048 Rubiera, Reggio Emilia - Italy

Tel +39.0522.623611
Fax +39.0522.629600

info@pa-etl.it

www.pa-etl.it



COMPANY WITH QUALITY MANAGEMENT
SYSTEM CERTIFIED BY DNV
= ISO 9001 =