

# NMT HT

Caratteristiche Tecniche

Albero maschio – Solid shaft

Technical Characteristics

Pump Pompa	Pressure Pressione		Volume Portata				RPM giri/min		Power Potenza			
			l/min		GPM				HP		kW	
	bar	PSI	50 Hz	60 Hz	50 Hz	60 Hz	50 Hz	60 Hz	50 Hz	60 Hz	50 Hz	60 Hz
NMT1220SHT	150	2175	12.5	15	3.3	4.0	1000	1200	4.8	5.8	3.5	4.2
NMT1520SHT	150	2175	15	18	4.0	4.7	1000	1200	5.8	6.9	4.2	5.1
NMT1220HT	150	2175	12.5	15	3.3	4.0	1450	1740	4.8	5.8	3.5	4.2
NMT1520HT	150	2175	15	18	4.0	4.7	1450	1740	5.8	6.9	4.2	5.1
NMT1820HT	150	2175	18	21.5	4.8	5.6	1450	1740	6.9	8.3	5.1	6.1
NMT2120HT	150	2175	21	25	5.5	6.6	1450	1740	8.1	9.7	5.9	7.1

Dimensioni d'ingombro

Overall dimensions

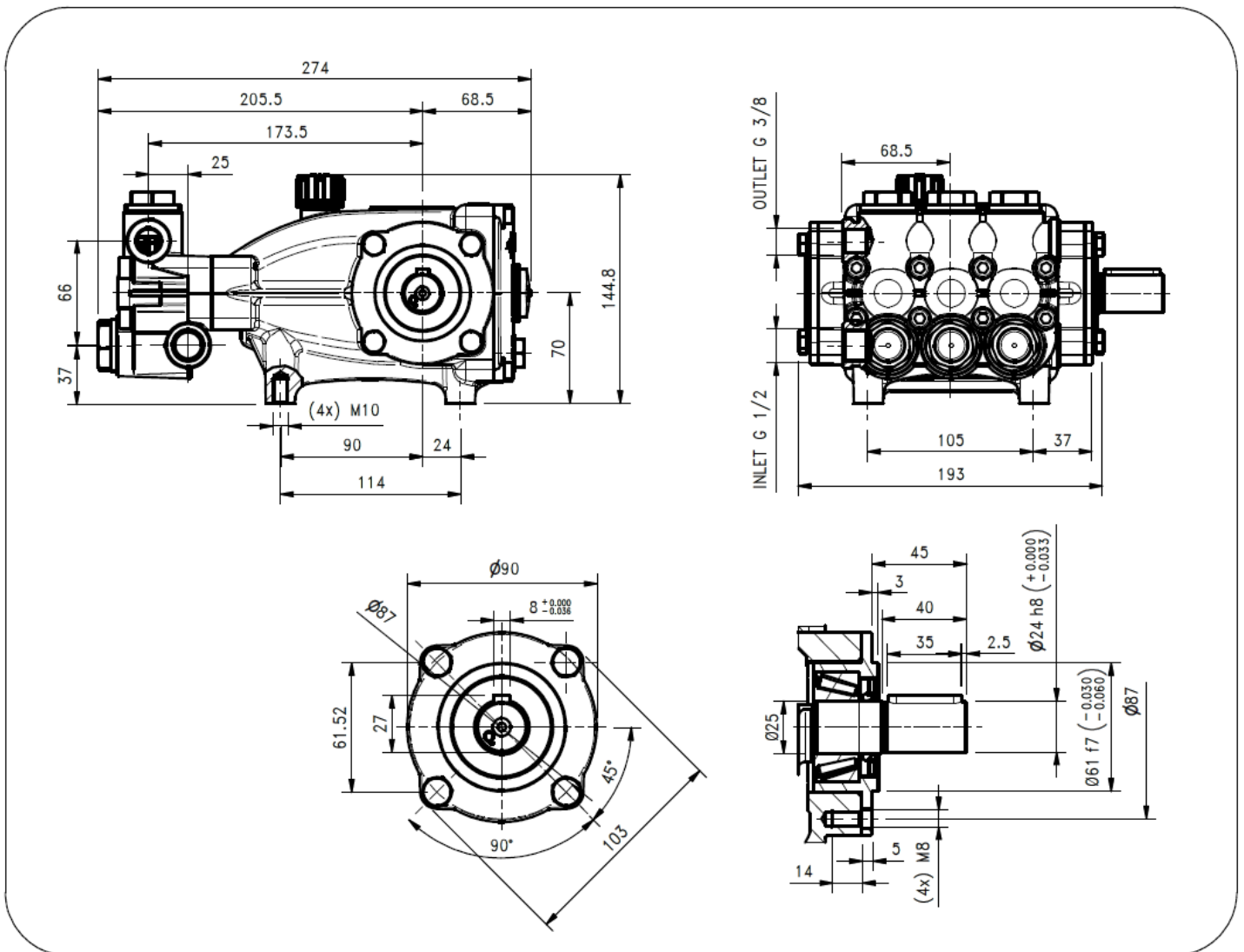

Lubrificazione: Olio SAE 10W40  
 Capacità: 0.7 Litri  
 Peso pompa: 10.3kg

Lubrication: SAE 10W40 Oil  
 Capacity: 0.7 Litres  
 Weight: 10.3 kg

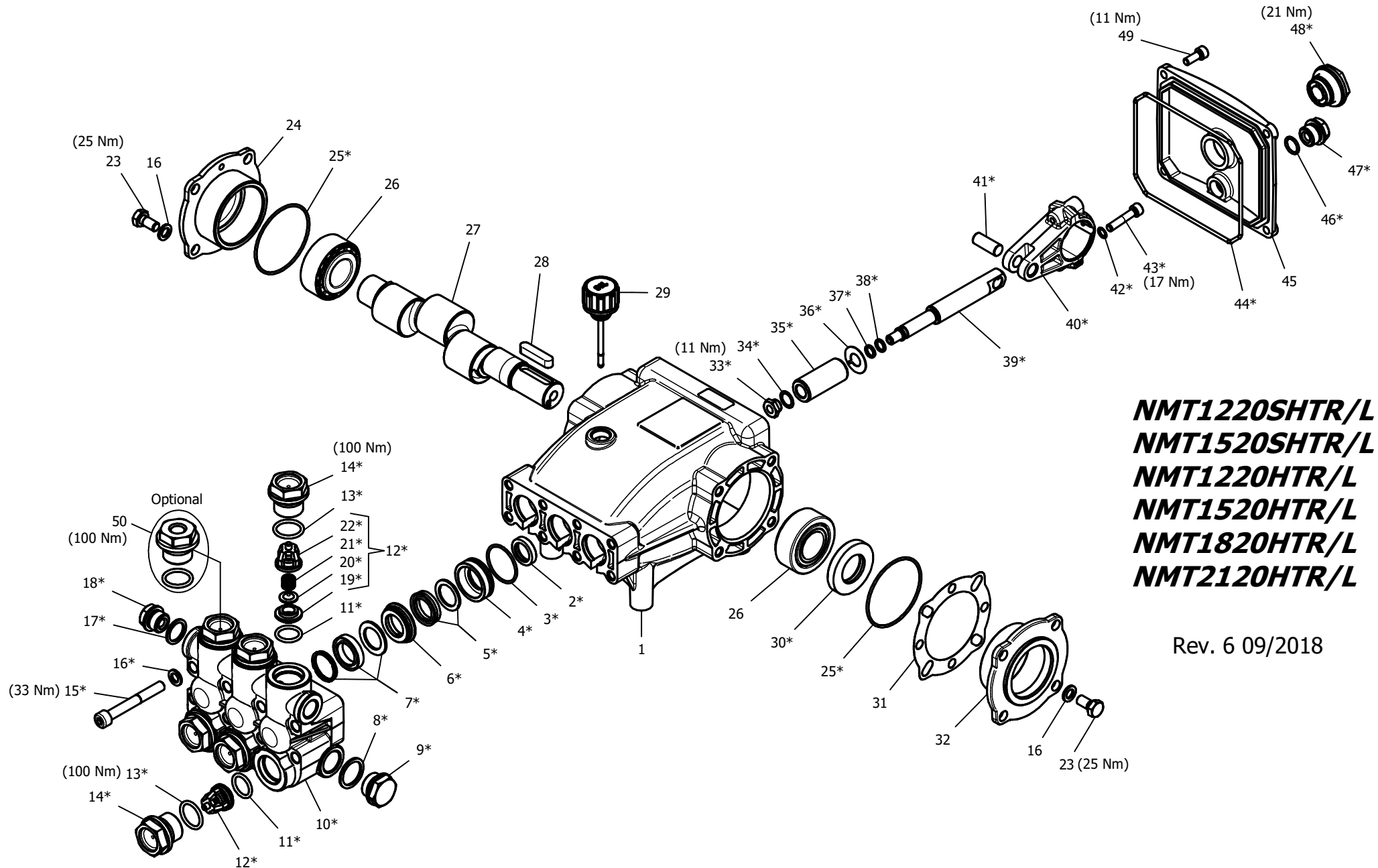

**NMT120SHTR/L**  
**NMT152SHTR/L**  
**NMT120HTR/L**  
**NMT152HTR/L**  
**NMT182HTR/L**  
**NMT212HTR/L**

Rev. 6 09/2018

**HAWK**  
**Pompe NMT HT serie 2011**  
**NMT HT pumps 2011 series**

## NMT HT 2011 SERIES

### ORDINARY MAINTENANCE KIT / KIT MANUTENZIONE ORDINARIA

KIT	Item Pos.	Part Number Codice	Description	Descrizione	Q.TY by Pump Q.TA per Pompa	NMT1220SHTR/L	NMT1520SHTR/L	NMT1220HTR/L	NMT1520HTR/L	NMT1820HTR/L	NMT2120HTR/L
A	3- 5- 7	1.905-844.0	PLUNGER SEALS DIA. 20 mm	GUARNIZIONI PISTONE Ø20	1						
B	11- 12- 13 (19- 20- 21 22)	1.905-708.0	COMPLETE VALVE	VALVOLA COMPLETA	1	•	•	•	•	•	•

### EXTRAORDINARY MAINTENANCE KIT / KIT MANUTENZIONE STRAORDINARIA

KIT	Item Pos.	Part Number Codice	Description	Descrizione	Q.TY by Pump Q.TA per Pompa	NMT1220SHTR/L	NMT1520SHTR/L	NMT1220HTR/L	NMT1520HTR/L	NMT1820HTR/L	NMT2120HTR/L
C	3- 4- 5- 6- 7	1.905-845.0	COMPLETE SEALS PACKING DIA. 20 mm	PACCO COMPLETO GUARNIZIONI PISTONE Ø20	1						
D	33- 34- 35 36- 37- 38	1.099-749.0	PLUNGER DIA. 20 mm	PISTONE Ø20	3						
E	2	1.099-751.0	PLUNGER OIL SEALS	ANELLI TENUTA OLIO ASTA	1						
F	25- 30- 44 46- 47- 48	1.905-542.0	KIT CRANKCASE SEALS	KIT TENUTE CARTER	1						
G	3- 4- 5- 6- 7 8- 9- 10- 11 12- 13- 14 15- 16- 17 18 (19- 20 21- 22)	1.099-854.0	COMPLETE MANIFOLD	TESTATA COMPLETA	1	•	•	•	•	•	•
H	33- 34- 37 38- 39- 40 41- 42- 43	1.905-544.0	CONNECTING ROD PLUNGER ROD ASSY	PREMONTATO ASTA-BIELLA PISTONE	3						
I	13- 14	1.904-133.0	VALVE PLUG ASSY	PREMONTATO TAPPO VAM	6						

“Q.TY by Pump” => Necessary quantity to repair one pump  
 “Q.TA’ per Pompa” => Quantità necessaria per riparare una pompa

### OPTIONAL

Item Pos.	Part Number Codice	Description	Descrizione	Q.TY by Pump Q.TA per Pompa	NMT1220SR/LN	NMT1520SR/LN	NMT1220R/LN	NMT1520R/LN	NMT1820R/LN	NMT2120R/LN
50	9.853-426.0	THREADED BRASS PLUG G1/4	PREMONTATO TAPPO FORATO	1	•	•	•	•	•	•

### TOOL KIT

Part Number Codice	Description	Descrizione	Q.TY by Pump Q.TA per Pompa	NMT1220SR/LN	NMT1520SR/LN	NMT1220R/LN	NMT1520R/LN	NMT1820R/LN	NMT2120R/LN
1.099-667.0	TOOL-KIT	TOOL-KIT	1	•	•	•	•	•	•
1.904-414.0	OIL SEAL EXTRACTOR TOOL-KIT	TOOL-KIT ESTRAZIONE PARAOLIO	1	•	•	•	•	•	•

#### IMPORTANT

#### IMPORTANTE

\* Part available **ONLY** in kit  
Disponibile **SOLO** in kit

(...) Parts pre-assembled  
Parti pre-assemblate

## PARTS LIST LISTA PARTI

Item Pos	Part Number Codice	Description	Descrizione	KIT	Q.TY Q.TÀ	NMT1220SHTR/L	NMT1520SHTR/L	NMT1220HTR/L	NMT1520HTR/L	NMT1820HTR/L	NMT2120HTR/L
1	9.850-375.0	CRANKCASE	CARTER		1						
2*		PLUNGER OIL SEAL	ANELLO RADIALE	E	3						
3*		"O" RING Ø1.78X31.47	"O" RING Ø1.78X31.47	A-C-G	3						
4*		PRESSURE RING 20MM	PRESSORE "U" Ø20	C-G	3						
5*		LOW PRESSURE "U" SEAL, DIA.20MM	ANELLO TENUTA "U" Ø20	A-C-G	3						
6*		INTERMED. RING 20MM	DIFFUSORE INTER. Ø20	C-G	3						
7*		HIGH PRESSURE "U" SEAL, DIA.20MM	ANELLO TENUTA "U" Ø20	A-C-G	3						
8*		COPPER WASHER G1/2	GUARNIZIONE RAME	G	1						
9*		BRASS PLUG G1/2 NICKEL PLATED	TAPPO G1/2 NICHELATO	G	1						
10*		MANIFOLD HOUSING NICKEL PLATED	TESTATA NICHELATA	G	1						
11*		"O" RING Ø2.62X17.13	"O" RING Ø2.62X17.13	B-G	6						
12*		VALVE ASSEMBLY	VALVOLA PREMONTATA	B-G	6						
13*		"O" RING Ø2.62X20.29	"O" RING Ø2.62X20.29	B-G-I	6						
14*		VALVE PLUG NICKEL PLATED	TAPPO VALVOLA NICHELATO	G-I	6	•	•	•	•	•	•
15*		MANIFOLD STUD BOLT M8X65 GEOMET	VITE M8X65 GEOMET	G	8						
16*		WASHER Ø8,5	ROSETTA Ø8.5	G	16						
17*		COPPER WASHER G3/8	GUARNIZIONE RAME	G	1						
18*		BRASS PLUG G3/8 NICKEL PLATED	TAPPO G3/8 NICHELATO	G	2						
19*		VALVE SEAT	SEDE VALVOLA	B-G	6						
20*		VALVE PLATE	PIATTELLO VALVOLA	B-G	6						
21*		VALVE SPRING	MOLLA VALVOLA	B-G	6						
22*		VALVE CAGE	GABBIA VALVOLA	B-G	6						
23	9.851-501.0	HEXAGONAL SCREW M8X18	VITE M8X18		8						
24	9.850-626.0	CLOSED BEARING HOUSING	FLANGIA CHIUSA		1						
25*		"O" RING Ø1.78X60.05	"O" RING Ø1.78X60.05	F	2						
26	9.850-349.0	ROLLER BEARING 33205	CUSCINETTO A RULLI 33205		2						
27	9.850-175.0	SINGLE - ENDED SHAFT	ALBERO SEMPLICE P.D.F.		1			•			
	9.850-177.0	" " "	" " "		1				•		
	9.850-178.0	" " "	" " "		1	•				•	
	9.850-179.0	" " "	" " "		1						•
	9.850-180.0	" " "	" " "		1		•				
28	9.850-446.0	CRANKSHAFT KEY	CHIAVETTA		1						
29	9.851-286.0	OIL DIP STICK	TAPPO LIVELLO OLIO		1						
30*		CRANKSHAFT SEAL	ANELLO RADIALE	F	1	•	•	•	•	•	•
31	9.850-547.0	SHIM	DISTANZIALE		1						
32	9.850-625.0	BEARING HOUSING	FLANGIA		1						

Item Pos	Part Number Codice	Description	Descrizione	KIT	Q.TY Q.TÀ	NMT1220SHTR/L	NMT1520SHTR/L	NMT1220HTR/L	NMT1520HTR/L	NMT1820HTR/L	NMT2120HTR/L
33*		PLUNGER NUT	DADO PISTONE	D-H	3						
34*		COPPER SPACER Ø 11.2/15X0.5	ROSETTA RAME Ø 1.2/15X0.5	D-H	3						
35*		PLUNGER 20MM	PISTONE Ø20	D	3						
36*		COPPER SPACER Ø 11.3/24X0.5	ROSETTA RAME Ø 1.3/24X0.5	D	3						
37*		"O" RING Ø1.78X7.66	"O" RING Ø1.78X7.66	D-H	3						
38*		TEFLON RING	ANELLO ANTIESTRUSIONE	D-H	3						
39*		PLUNGER ROD	ASTA PISTONE	H	3						
40*		CONNECTING ROD	BIELLA	H	3						
41*		CONNECTING ROD PIN	SPINOTTO	H	3	•	•	•	•	•	•
42*		SPRING WASHER Ø6	ROSETTA ELASTICA Ø6	H	6						
43*		CONNECTING ROD SCREW M6X30	VITE M6X30	H	6						
44*		"O" RING Ø 2.62X126.67	"O" RING Ø 2.62X126.67	F	1						
45	9.850-388.0	CRANKCASE COVER	COPERCHIO POSTERIORE		1						
46*		"O" RING Ø1.78X14	"O" RING Ø1.78X14	F	1						
47*		BRASS PLUG G 3/8	TAPPO G 3/8	F	1						
48*		SIGHT GLASS, G3/4	SPIA LIVELLO OLIO G3/4	F	1						
49	9.851-474.0	SCREW M6X16	VITE M6X16		4						