

MANHOLE CLEANER

- ✓ With protection plate
- ✓ Optimal cleaning of vertical main
- ✓ Easy to use

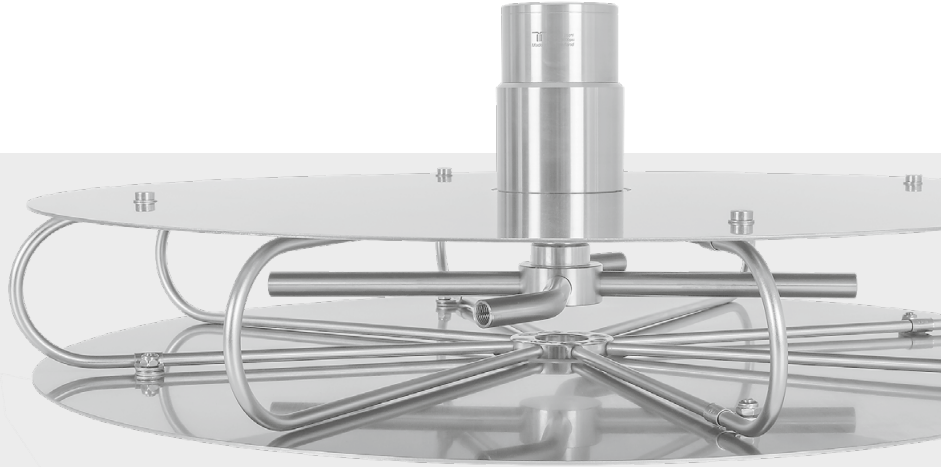

Mosmatic Manhole cleaner is ideal for the restoration, cleaning and service of manholes, liftstations and other long vertical drops. Easy to use self rotating equipment made for higher flow rates. Stainless Steel protection plate included. Choose from a variety of sizes.



TECHNICAL DATA

Pressure 170 bar
Temperature 120°C
Inlet G1/2" F (TXS-2f)
 G1" F (TXS-4f)
Body stainless steel
Nozzles* für 2x 1/8" (TXS-2f)
 für 4x 1/8" (TXS-4f)
Throughput ph 3 - 12

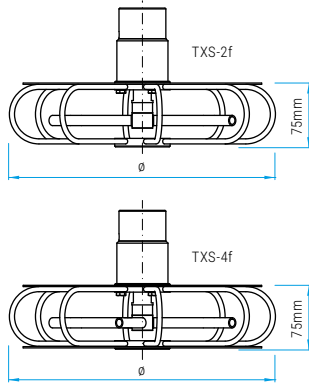

TXS-2f with protective plate

Part No.	ø	Weight
81.033	300	3.7kg
81.043	400	4.4kg
81.053	500	5.3kg
81.063	600	6.4kg
81.083	800	9.5kg

TXS-4f with double protective plate

Part No.	ø	Weight
81.937	400	5.4kg
81.938	500	7.0kg

* Nozzles not included.

Important: Do not use unprotected!

SILO CLEANER

- ✓ Adjusts to your application
- ✓ Equipped with stabilizer nozzles
- ✓ Completely maintenance-free



Mosmatic has a solution for cleaning Silo's and other large diameter vertical drops. The extendable arms with rollers help guide and maintain a close surface cleaning impact. Simply attach a suspension cable to the eyelets and use your winch to raise and lower the Silo Cleaner. Stabilizer nozzles increase the cleaning distance and impact and maintain a more concentrated spray pattern. Stainless steel construction and maintenance free design help to ensure long life and reliability.



Silo-R

Part No.	Length/Width	Height	Rotor Arm	Nozzles	Wheels	Weight
81.091	2040 - 3500mm	210mm	82.9036	2x 18.050EG	4x ø100	25kg

FEATURES

Variable Lengths & Foldable

The length of the rotating arm is easily adjusted from 2040 up to 3500mm. Folding the Silo Cleaner allows for a tight fit into the Silo loading port.

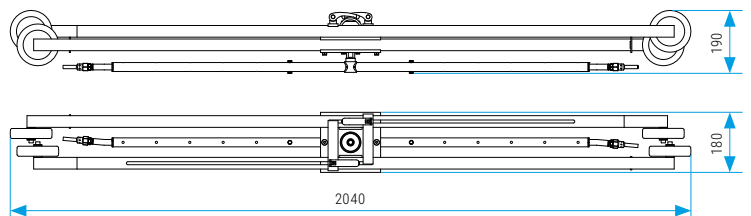
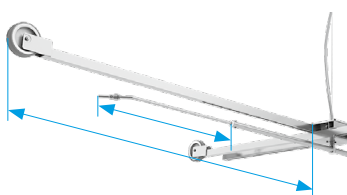

TECHNICAL DATA

Pressure 170 bar
Temperature 120°C
Inlet G1/2" F